



SUPREME HEATING
VORTEXPRO



INSTALLATION AND USER MANUAL

Summary

For usersP.3-P.11

>	1. General information:.....	- 3 -
	1.1. Contents:.....	- 3 -
	1.2. Operating conditions and range:	- 3 -
	1.3. Advantages of different modes:	- 4 -
	1.4. Kind reminder:	- 4 -
>	2. Operations.....	- 6 -
	2.1. Notice before using.....	- 6 -
	2.2. Operation instructions.....	- 6 -
>	3. Technical specification	- 14 -

For installers and professionals P.12-P.29

>	1. Transportation.....	- 15 -
>	2. Installation and maintenance.....	- 15 -
	2.1. Notice before installation:	- 15 -
	2.2. Installation instruction.....	- 16 -
	2.3. Trial after installation.....	- 20 -
	2.4. Maintenance and winterizing	- 21 -
>	3. Trouble shooting for common faults	- 21 -
>	4. Failure code	- 22 -
	APPENDIX 1: HEATING PRIORITY WIRING DIAGRAM (OPTIONAL).....	- 23 -
	APPENDIX 2: HEATING PRIORITY WIRING DIAGRAM (OPTIONAL).....	- 24 -
	APPENDIX 3: HEATING PRIORITY WIRING DIAGRAM (OPTIONAL).....	- 25 -
	5. Wi-Fi Setting.....	- 26 -
	6.OPTIONAL CONTROLLERS - Vortex Link and Switch.....	- 33 -

Please read it carefully and keep it for subsequent use.

This manual provides you necessary information for optimal use and maintenance. This appliance is not intended for use by persons (including children) with reduced physical, sensory or mental capabilities, or lack of experience and knowledge, unless they have been given supervision or instruction concerning use of the appliance by a person responsible for their safety.



Warning:

- a. Please read the following tips before installation, use and maintenance.
- b. Installation, removal and maintenance must be carried out by Professional in accordance with the instructions.
- c. Gas leakage test must be done before and after installation.

1. Use

- a. It must be installed or removed by professionals, and it is forbidden to dismantle and refit without permission.
- b. Don't put obstacles before the air inlet and outlet of the heat pump.

2. Installation

- a. This product must be kept away from any source of fire.

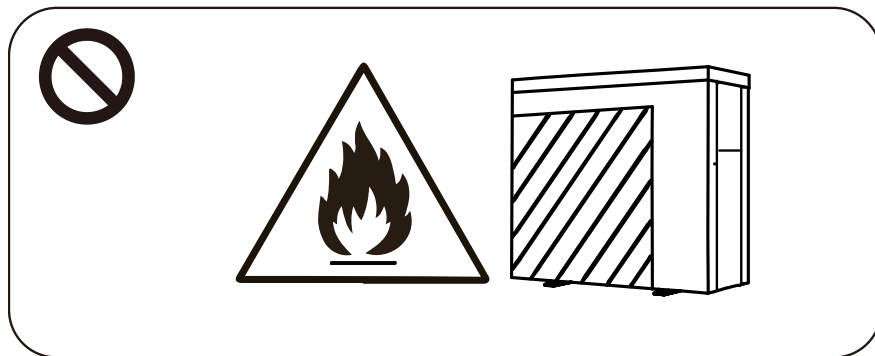

- b. The installation can't be in a closed environment or indoors, and must be kept well ventilated.

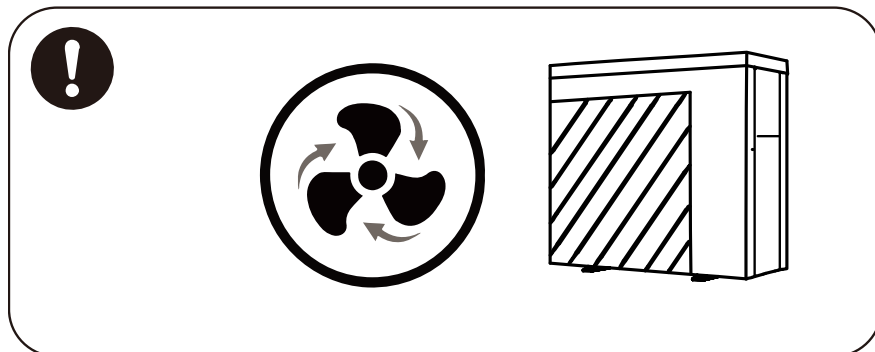

- c. Vacuum completely before welding, field welding is not allowed, welding can only be performed by professional personnel in professional maintenance center.

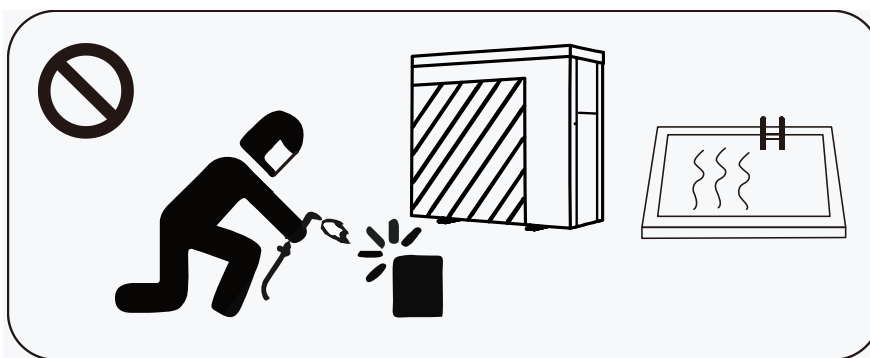

- d. Installation must be stopped if any gas leakage, and the unit must be returned to professional maintenance center.

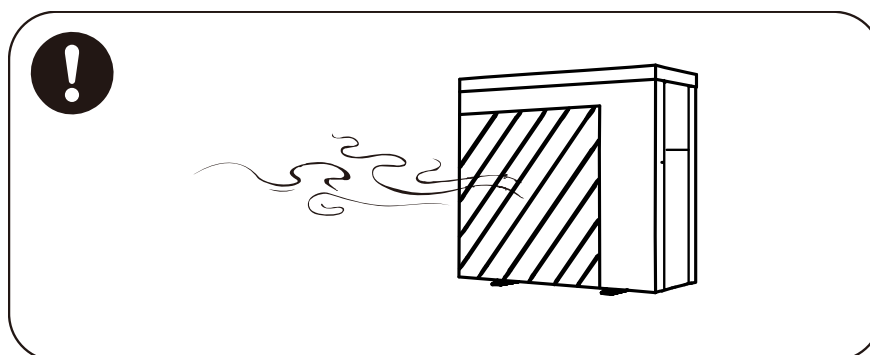

3. Transportation and Storage

- a. Sealing is not allowed during transportation
- b. Transporting goods at a constant speed is needed to avoid sudden acceleration or sudden braking, so as to reduce the collision of goods.
- c. The unit must be far away from any source of fire.
- d. Storage place must be bright, wide, open and good ventilation, ventilation equipment is required.

4. Maintenance Notice

- a. If maintenance or scrap is required, contact an authorized service center nearby
- b. Qualification requirement
All operators who dispose gas must be qualified by valid certification which issued by professional agency.
- c. Please strictly comply with the requirement from manufacturer when maintenance or filling gas. please refer to the technical service manual.

> 1. General information:

1.1. Contents:

After unpacking, please check if you have all the following components.

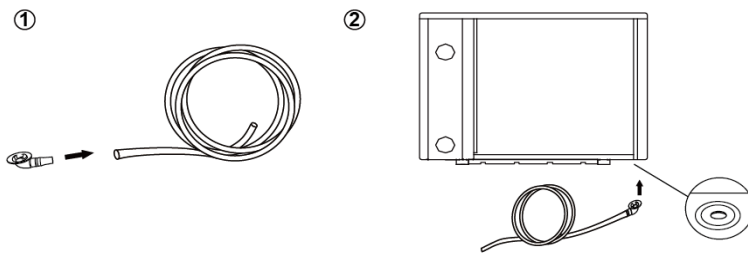
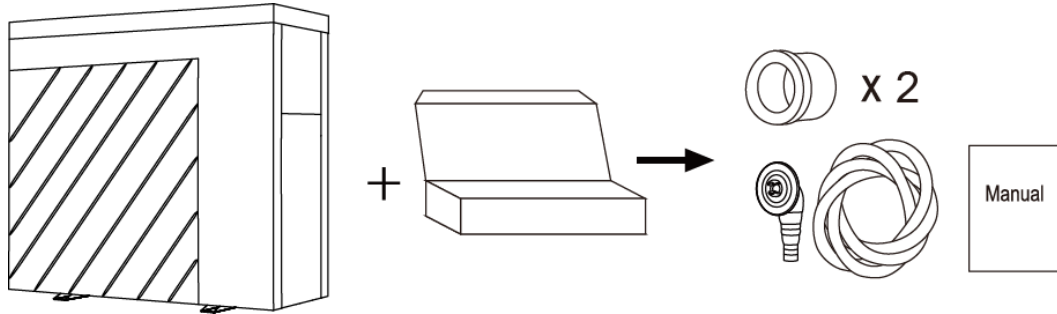

NOTICE:

Please install the water unions step by step.

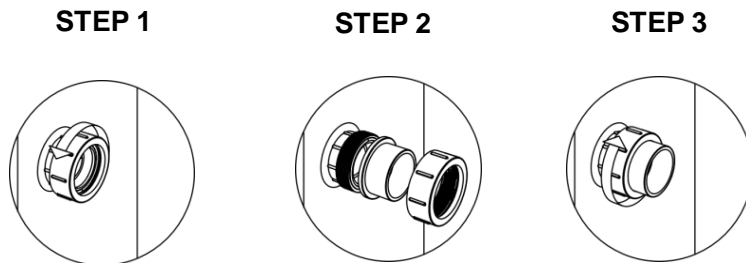



1.2. Operating conditions and range:

ITEMS		RANGE
Operating range	Air temp	-7°C ~ 43°C / 19°F ~ 109°F
Temp. setting	heating	18°C ~ 40°C / 64°F ~ 104°F
	cooling	12°C ~ 30°C / 54°F ~ 86°F

The heat pump will have ideal performance in the operation range Air 15°C ~ 25°C / 59°F ~ 77°F.

1.3. Advantages of different modes:

The heat pump has two modes: Smart and Silence. They have different advantages under different conditions

MODE	RECOMMENDATION	ADVANTAGES
	Smart mode As standard	Heating capacity: 20% to 100% capacity Intelligent optimization Fast heating
	Silence mode Use at night	Heating capacity: 20% to 80% capacity Sound level: 3dB (A) lower than Smart mode.

1.4. Kind reminder:

 This heat pump has Power-off memory function. When the power is recovered, the heat pump will restart automatically.

1.4.1. The heat pump can only be used to heat the pool water. It can NEVER be used to heat other flammable or turbid liquid.

1.4.2. Don't lift the water union when moving the heat pump since the titanium heat exchanger inside the heat pump will be damaged.

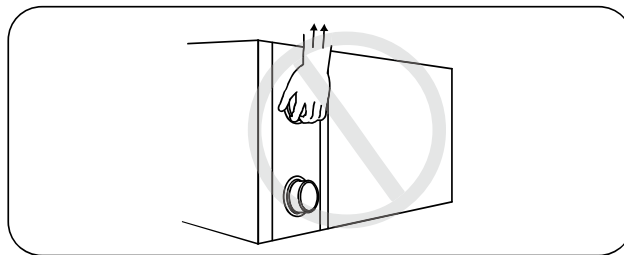

1.4.3. Don't put obstacles before the air inlet and outlet of the heat pump.

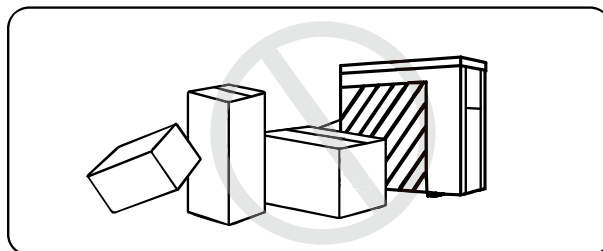

1.4.4. Don't put anything into inlet or outlet, or the efficiency of the heat pump will be reduced or even stopped.

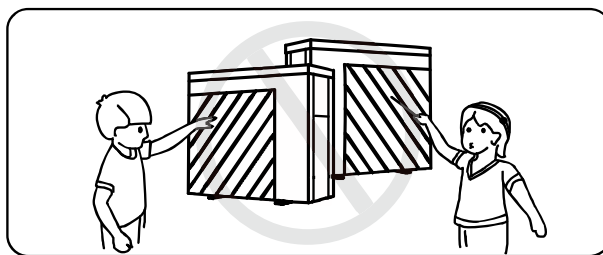

1.4.5. Don't use or store combustible gas or liquid such as thinners, paint and fuel to avoid fire.

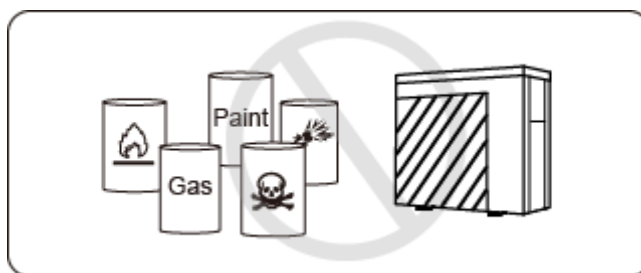

1.4.6. If any abnormal circumstances occurred, e.g.: abnormal noises, smells, smokes and leakage of electricity, switch off the main power immediately and contact your local dealer. Don't try to repair the heat pump by yourselves.

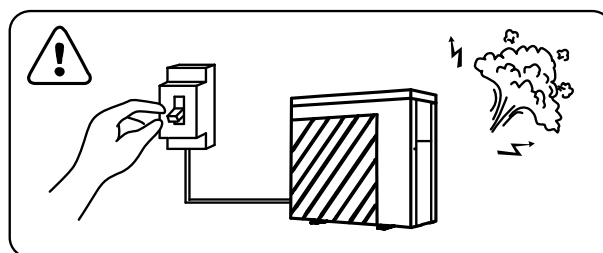

1.4.7. The main power switch should be out of the reach of Children.

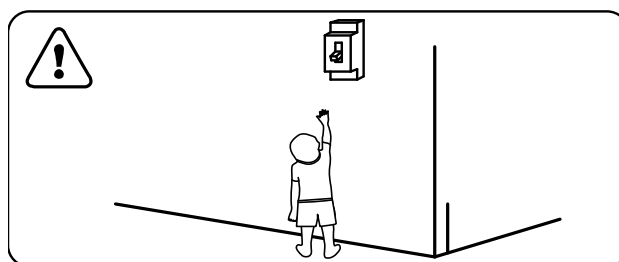

1.4.8. Please cut off the power in the lightning storm weather.

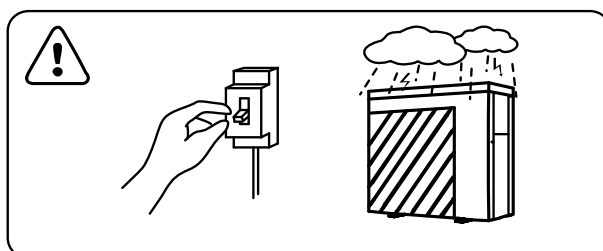

1.4.9. Please note that following codes are not failure.

	Codes
No water flow	E3
Anti-Freezing Reminder	Ed
Out of the operating range	Eb
Insufficient water flow or pump blocked	E6
Power abnormal	E5

> 2. Operations





2.1. Notice before using

- ① For longer service life, please ensure water pump is on before heat pump is on, and water pump is off after heat pump is off.
- ② Ensure no water leakage on piping system, then unlock screen and power on heat pump.

2.2. Operation instructions

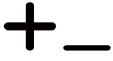

SYMBOL	DESIGNATION	FUNCTION
⏻	ON/OFF	1. Power On/Off 2. Wifi setting

	Lock/Unlock Mode Selection	1. Press it for 3 seconds to unlock/lock screen 2. After screen is unlocked, press it to select mode. Auto 12~40°C / 54°F~104°F Heating 18~40°C / 64°F~104°F Cooling 12~30°C / 54°F~86°F
	Speed	Select Smart/Silence mode
	Up / Down	Adjust set temperature
	Timer	Time and timer setting

Note:







① Screen lock:



- a. If no operation in 30 seconds, screen will be locked.
- b. When HP is off, screen will be dark and "0%" will be displayed.
- c. Press  for 3 seconds to lock screen and it will be dark



② Screen unlock:

- a. Press  for 3 seconds to unlock screen and it will be lit up.
- b. Only after screen is unlocked, any other buttons can be functioned.





	Auto
	Heating
	Cooling
	Heating capacity percentage
	Wi-Fi connection
	Water inlet
	Water outlet

1. Power On: Press  for 3 seconds to light up screen, then press  to power on heat pump.

2. Adjust Set Temperature: When screen is unlocked, press  or  to display or adjust the set temperature.

3. Mode Selection: Press  to select mode.

a. Auto : adjustable temperature range 12~40°C / 54°F~104°F



b. Heating : adjustable temperature range 18~40°C / 64°F~104°F

c. Cooling : adjustable temperature range 12~30°C / 54°F~86°F

4. Smart/Silence mode selection:







① Smart mode as default will be activated when heat pump is on, and screen shows



② Press  to enter Silence mode, and screen shows 
(Suggestion: select Smart mode for initial heating)

5. Timer

The timer function is a 24-hour system, please calibrate with local time.

a. Real time setting: Press  for 5 seconds to enter real time setting, press  or  to adjust the hour. After completion, press  switch to minute setting. And then press  to confirm. During real time setting, you can press  once to cancel the setting.

b. Time display

When the machine is off, the time display on the top right corner is real time.

When the machine is on, the real time can be shown 10 seconds if you press timer once.

c. Timer setting

Press  for 10 seconds and release when you hear the "beep" sound to enter the timer setting.

(1) Timer on setting, **1** will be flashing.

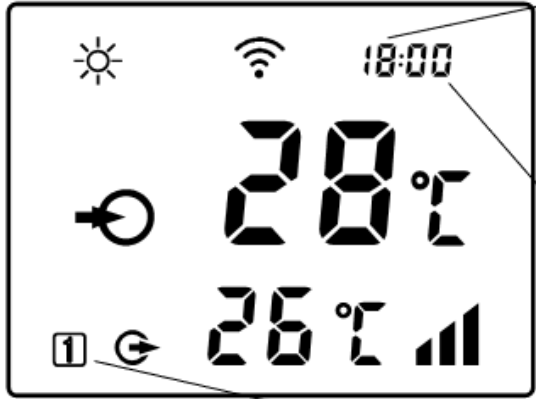



1. Hours flashing, press **+** or **-** to set the hour.
Press  to confirm the hour to turn on.

2. Minutes flashing, press **+** or **-** to set the minute.
Press  to confirm the minute to turn on.

3. When the time is flashing, press  once to turn on cycle.

Finally, press  once to confirm timer on setting.

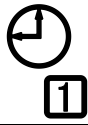
The icon in the lower left corner indicates as below:

	Timer on every day
	Timer on one time
No symbol	No timer setting

(2) Timer off setting, **0** will be flashing.

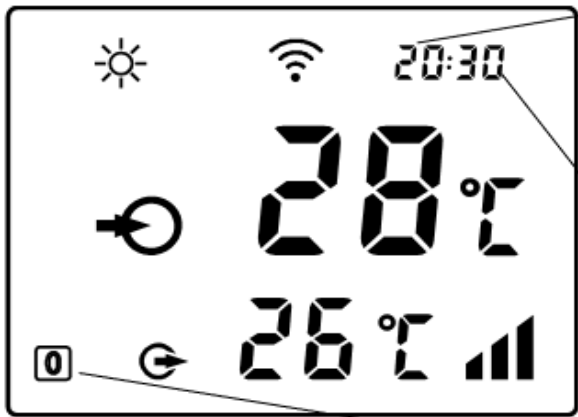



1. Hours flashing, press **+** or **-** to set the hour.
Press  to confirm the hour to turn off.

2. Minutes flashing, press **+** or **-** to set the minute.
Press  to confirm the minute to turn off.

















3. When the time is flashing, press  once to turn on cycle.

Finally, press  once to confirm timer off setting.

The icon in the lower left corner indicates as below:





 	Timer off every day
	Timer off one time
No symbol	No timer setting

(3) After setting, the icon in the lower left corner indicates as below:

  	Timer on every day	Timer off every day
  and  alternate display	Timer on every day	Timer off one time
 	Timer on every day	No timer off
  and  alternate display	Timer on one time	Timer off every day
 	No timer on	Timer off every day
 	Timer on one time	Timer off one time
	Timer on one time	No timer off
	No timer on	Timer off one time
No symbol	No timer on	No timer off

6. Defrosting

a. Auto Defrosting: When heat pump is defrosting,  will be flashing. After defrosting,  will stop flashing.

b. Compulsory Defrosting: When heat pump is heating, press  and  together for 5 seconds to start compulsory defrosting, and  will be flashing. After defrosting,  will stop flashing.

(Note: Compulsory defrosting intervals should be more than 30 minutes and the compressor should run for more than 10 minutes at heating model.)

7. Temperature display conversion between °C and °F:



Press "" and "" together for 5 seconds to switch between °C and °F.

8. Wifi setting

Please kindly check the last page.





2.3. Advanced application

2.3.1 Parameter Checking

a. Press  and  together for 5 seconds to enter "Parameter Checking" status, the parameter code "P0" and the parameter value "0" will display on the screen, such as "P0 0", which means water pump running way is continuous.

b. In "Parameter Checking" status, press  or  to check the parameters.





2.3.2 Parameter Modification

In "Parameter Checking" status, press  to enter the "Parameter Modification" mode, press  or  to change the values, then press  to confirm and quit "Parameter Modification" mode, press  to quit "Parameter Checking" status.

2.3.3 Parameter list

NO.	Content	Adjust range	Step length
P0	Water Pump Running Way	0: Continuous 1: Water temp control 2: Time/water temp control	1
P1	Time Setting (Only available when the water pump running way is set to "2")	10 ~ 120 min	5 min
P2	Compressor Continuously Running Time between Defrosting Mode	30 ~ 90min	1min
P3	Defrosting EntryTemp	-17 ~ 0 °C / 1 ~ 32 °F	1°C / 1°F
P4	Maximum Defrosting Running Time	1 ~ 12min	1min
P5	Defrosting ExitTemp	8 ~ 30°C / 46 ~ 86 °F	1°C / 1°F

2.3.4 Running status checking

Press  for 5 seconds, enter into "Running status checking", and the screen alternately shows status point "C0" and its corresponding value. Check all status points and their corresponding value through  or , Press  to quit "running status checking" mode.

Running status checking list

Symbol	Content	Unit
C0	Inlet water temp.	°C/°F
C1	Outlet water temp.	°C/°F
C2	Ambient temp.	°C/°F
C3	Exhaust temp.	°C/°F
C4	Outer coil pipe temp. (Evaporator)	°C/°F
C5	Gas return temp.	°C/°F
C6	Inner coil pipe temp. (Titanium heat exchanger)	°C/°F
C9	Cooling plate temp.	°C/°F
C10	Electronic expansion valve opening	P
C11	DC fan speed	(r/min)

2.4. Daily maintenance and winterizing

2.4.1. Daily Maintenance



Please don't forget to cut off power supply of the heat pump

- Please clean the evaporator with household detergents or clean water, NEVER use gasoline, thinners or any similar fuel.
- Check bolts, cables and connections regularly.

2.4.2. Winterizing

In winter season when you don't swim, please cut off power supply and drain water out of the heat pump. When using the heat pump under 2°C /36°F, make sure there is always water flow.

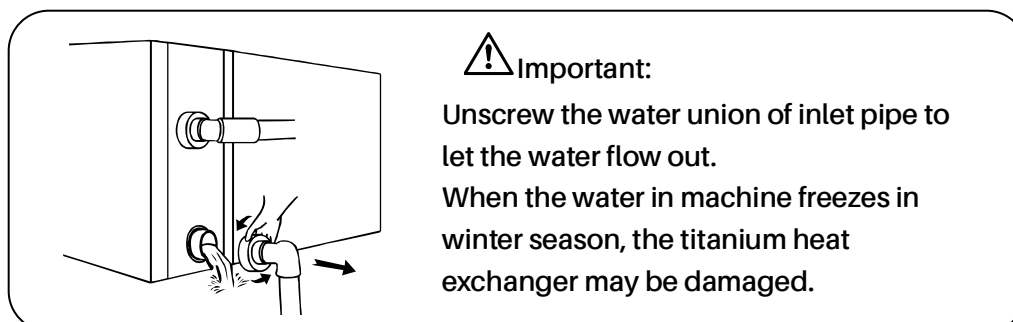

! Important:

Unscrew the water union of inlet pipe to let the water flow out.

When the water in machine freezes in winter season, the titanium heat exchanger may be damaged.

> 3. Technical specification

Model	VortexPro 10	VortexPro 13	VortexPro 17	VortexPro 21	VortexPro 28	VortexPro 35T
Advised pool volume (m ³)	25~45	30~55	40~75	50~95	65~120	90~160
Working air temp (°C)	7°C~43°C/19°F~109°F					
Performance Condition: Air 26°C / 80°F, Water 26°C / 80°F, Humidity 80%						
Heating capacity (kW)	10.3	12.8	17.3	20.4	27.3	35.6
C.O.P	14.5~6.9	15.0~7.4	14.8~5.9	14.5~5.7	14.6~6.2	15.5~5.5
C.O.P at 50% speed	10.4	11.0	10.5	10.2	10.8	10.3
Performance Condition: Air 15°C / 59°F, Water 26°C / 80°F, Humidity 70%						
Heating capacity (kW)	7.1	8.9	11.4	14.0	18.0	24.0
C.O.P	7.3~4.6	7.7~4.8	7.5~4.3	7.4~4.2	7.8~4.6	7.7~4.5
C.O.P at 50% speed	6.4	6.8	6.1	6.1	6.5	6.8
Performance Condition: Air 35°C / 95°F, Water 28°C / 82°F, Humidity 80%						
Cooling capacity (kW)	4.5	5.5	7.7	9.8	12.1	16.4
Rated input power(kW) at air 15°C/ 59°F	0.19~1.5	0.22~1.73	0.3~2.6	0.38~3.3	0.57~3.8	0.62~5.2
Rated input current(A) at air 15°C / 59°F	0.83~6.5	0.96~7.52	1.3~11.3	1.65~14.3	2.48~16.5	0.89~7.4
Power supply	230V/1 Ph/50Hz					400V/3 Ph/50Hz
Advised water flux (m ³ /h)	3~4	4~6	6.5~8.5	8~10	10~12	12~18
Sound pressure 1m dB(A)	38.6~49.9	42.1~50.7	43.1~53.8	40.9~54.2	43.5~54.9	42.6~54.7
Sound pressure 10m dB(A)	18.6~29.9	22.1~30.7	23.1~33.8	20.9~34.2	23.5~34.9	22.6~34.7
Water pipe in-out Spec (mm)	48.3					
Net Dimension LxWxH (mm)	894×359× 648	954×359× 648	954×429× 648	954×429× 755	1084×429× 948	1154×539× 948
Net Weight (kg)	49	50	63	68	90	120

1. The values indicated are valid under ideal conditions: Pool covered with an isothermal cover, filtration system running at least 15 hours a day.
2. Related parameters are subject to adjustment periodically for technical improvement without further notice. For details please refer to nameplate.

> 1. Transportation

1.1. When storing or moving the heat pump, the heat pump should be at the upright position.

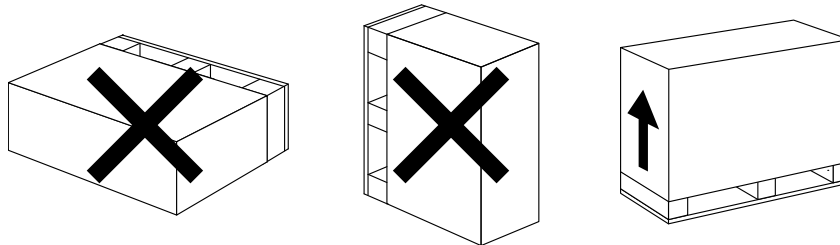

1.2. When moving the heat pump, do not lift the water union since the titanium heat exchanger inside the heat pump will be damaged.

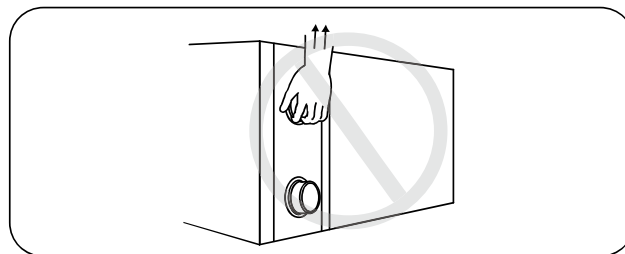

> 2. Installation and maintenance

! The heat pump must be installed by a professional team. The users are not qualified to install by themselves, otherwise the heat pump might be damaged and risky for users' safety.

2.1. Notice before installation :

2.1.1. The inlet and outlet water unions can't bear the weight of soft pipes. The heat pump must be connected with hard pipes!

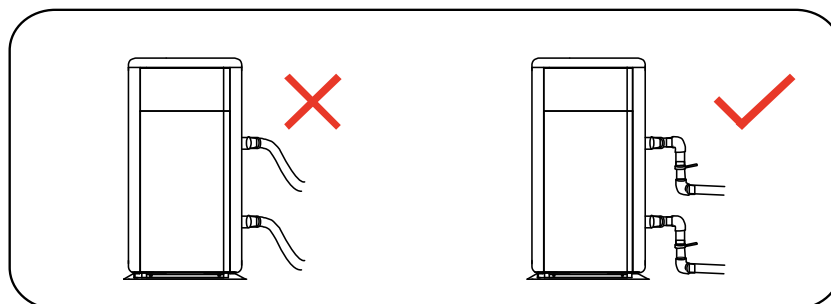

2.1.2. In order to guarantee the heating efficiency, the water pipe length should be $\leq 10\text{m}$ between the pool and the heat pump.

2.2. Installation instruction

2.2.1. Location and size

⚠ The heat pump should be installed in a place with good ventilation

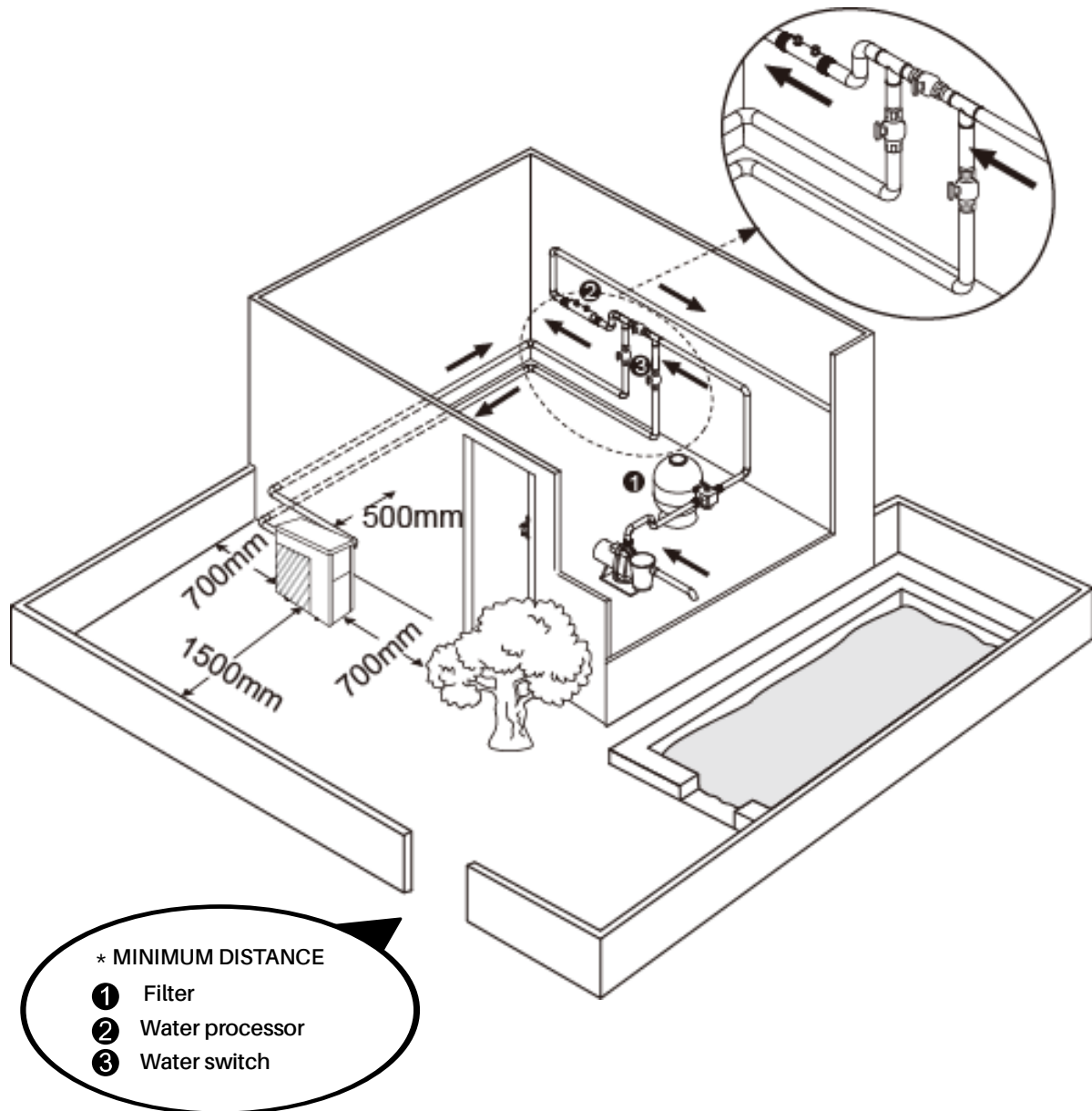

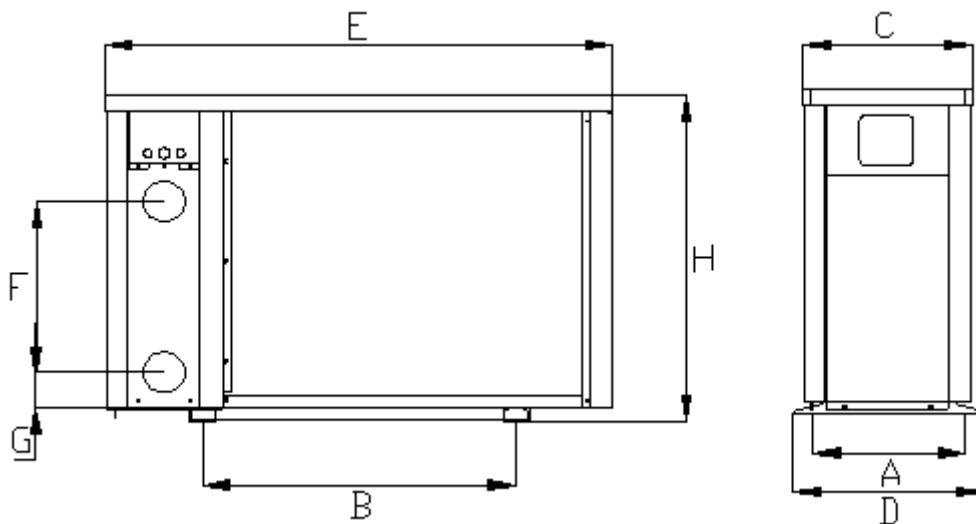

UNIT=MM		A	B	C	D	E	F	G	H
MODEL	VortexPro 10	334	590	318	359	894	290	74	648
	VortexPro 13	334	590	318	359	954	280	74	648
	VortexPro 17	404	590	388	429	954	390	74	648
	VortexPro 21	404	590	388	429	954	460	74	755
	VortexPro 28	404	720	388	429	1084	620	74	948
	VortexPro 35T	514	790	498	539	1154	650	74	948

※ Above data is subject to modification without notice.

2.2.2. Heat pump installation.

- The frame must be fixed by bolts (M10) to concrete foundation or brackets. The concrete foundation must be solid; the bracket must be strong enough and anti-rust treated;
- The heat pump needs a water pump (Supplied by the user). The recommended pump specification-flux: refer to Technical Parameter, Max. lift $\geq 10\text{m}$
- When the heat pump is running, there will be condensation water discharged from the bottom, please pay attention to it. Please insert the drainage tube (accessory) into the hole and clip it well, then connect a pipe to drain off the condensation water.

2.2.3. Wiring and protecting devices and cable specification

- Connect to appropriate power supply, the voltage should comply with the rated voltage of the products.
- Well earth the heat pump.
- Wiring must be connected by a professional technician according to the circuit diagram.
- Set breaker or fuse according to the local code (leakage operating current $\leq 30\text{mA}$).
- The layout of power cable and signal cable should be orderly and not affecting each other. Considering the environmental conditions (ambient temperature, direct sunlight, rain, grid voltage, cable length, etc.), the cross-sectional area of the cable can be appropriately increased.

! 1. Connecting your power wire

VortexPro 10 ~ VortexPro 17

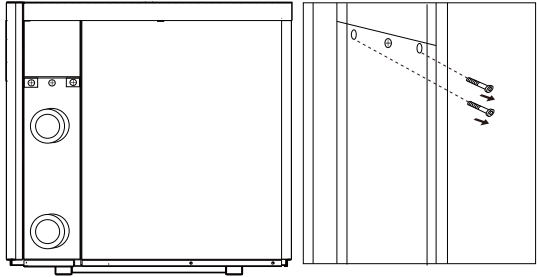
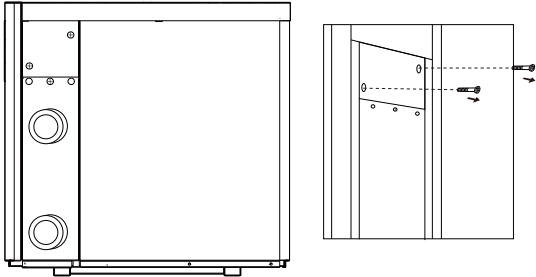
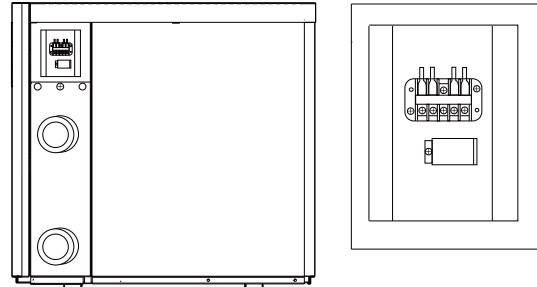
	
	<p>1 2 3</p> <ul style="list-style-type: none"> ✧ Remove the two screws and take away the external panel. ✧ Remove the two screws and take away the cover of terminal box. ✧ Find the terminal plate and connect according to electric wiring diagram.

VortexPro 21 ~ VortexPro 35T

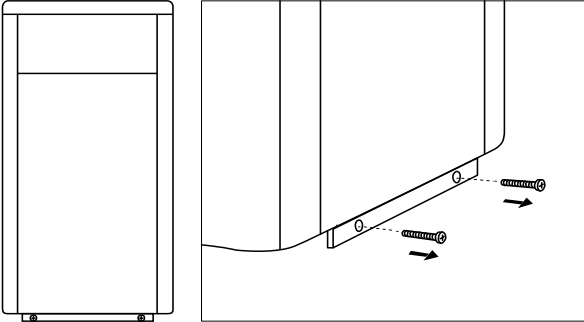
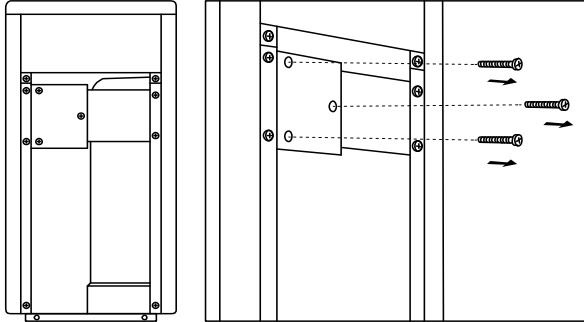
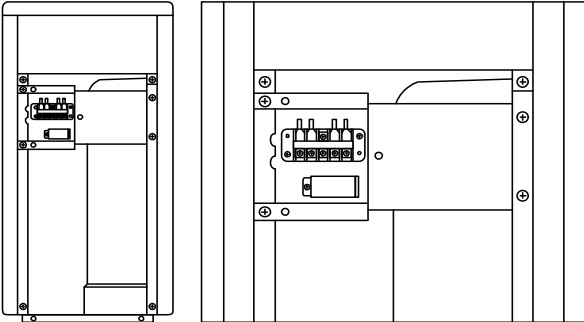
	
	<p>1 2 3</p> <ul style="list-style-type: none"> ✧ Remove the two screws in the bottom of right-side panel and take away the right down panel. ✧ Remove the three screws and take away the cover of terminalplate. ✧ Find the terminal plate and connect the wire according to electric wiring diagram.

Note: For VortexPro 10~ VortexPro 13 model, please open the back panel for power connection. The operation is the same as above.

⚠️ 2. Wiring diagram

A. For power supply: 230V 50Hz

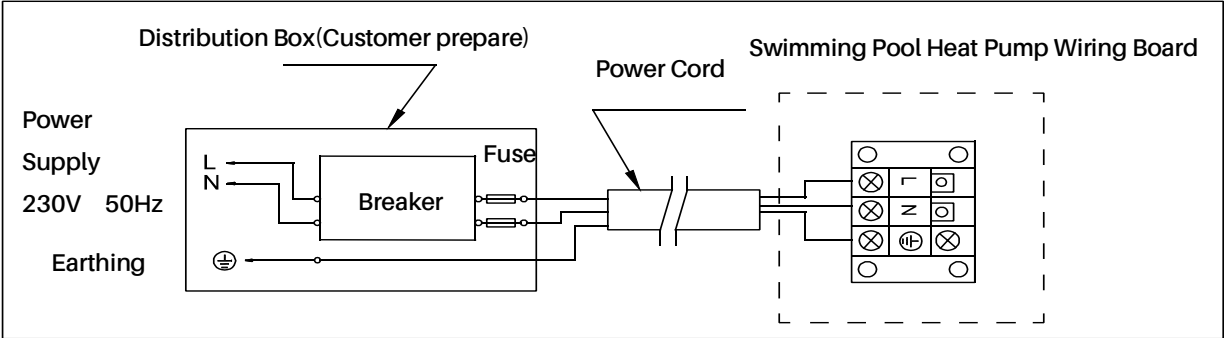

B. For power supply: 400V 50Hz

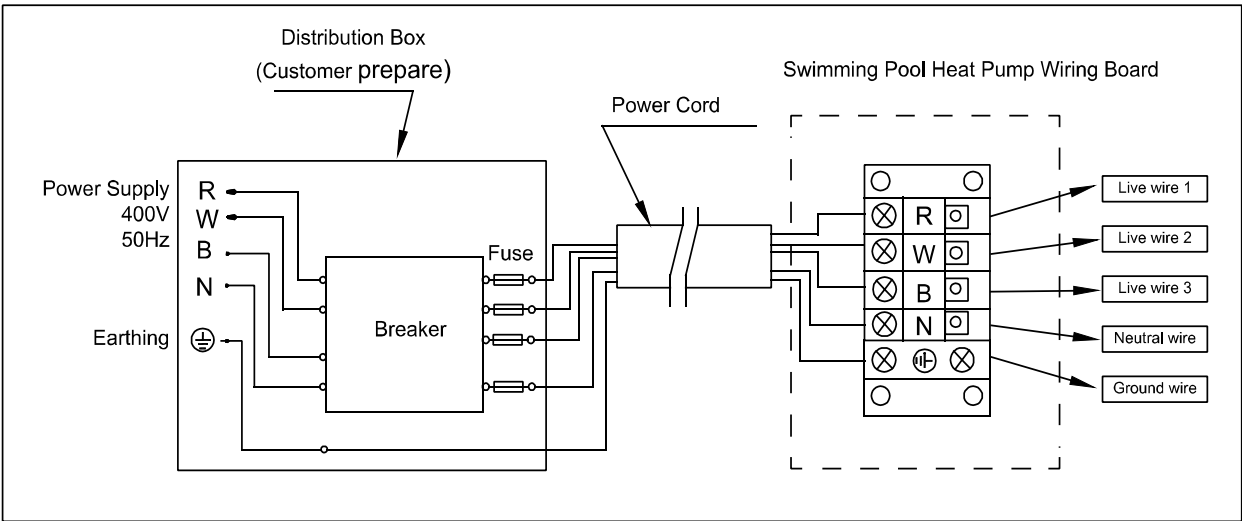

NOTE:

⚠️ Must be hard wired, no plug allowed (In Australia, VortexPro 13 has plug for optional)

- For your safe use in winter, it's strongly recommended to equip heating priority function.
- For the detailed wiring diagram, please refer to Appendix 1.

⚠️ 3. Options for protecting devices and cable specification

MODEL		VortexPro 10	VortexPro 13	VortexPro 17	VortexPro 21	VortexPro 28	VortexPro 35T
Breaker	Rated Current A	12.0	14.5	18.0	21.0	24.0	12.0
	Rated Residual Action Current mA	30	30	30	30	30	30
Max input current (A)		10.0	12.0	15.0	17.0	20.0	9.5
Fuse A		12.0	14.5	18.0	21.0	24.0	12.0
Power Cord (mm ²)		3×2.5	3×2.5	3×4	3×4	3×6	5x2.5
Signal cable (mm ²)		3×0.5	3×0.5	3×0.5	3×0.5	3×0.5	3×0.5

NOTE: The above data is adapted to power cord ≤ 10m .If power cord is > 10m, wire diameter must be increased. The signal cable can be extended to 50m at most.

2.3. Trial after installation

⚠️ Please check all the wirings carefully before turning on the heat pump.

2.3.1. Inspection before use

- Check installation of the whole heat pump and the pipe connections according to the pipe connecting drawing;
- Check the electric wiring according to the electrical wiring diagram and earthing connection;
- Make sure that the main power is well connected;
- Check if there is any obstacle in front of the air inlet and outlet of the heat pump

2.3.2. Trial

- The user is advised to start the water pump before the heat pump, and turn off the heat pump before the water pump for long life circle.
- The user should start the water pump, and check for any leakage of water; Power on and press the ON/OFF button of the heat pump, and set desired temperature in the thermostat.
- In order to protect the heat pump, the heat pump is equipped with start delay function. When starting the heat pump, the fan will start to run in 3 minutes, in another 30 seconds, the compressor will start to run.
- After pool heat pump starts up, check for any abnormal noise from the heat pump.
- Check the temperature setting

2.4. Maintenance and winterizing

2.4.1 Maintenance

⚠ The maintenance should be carried out once per year by qualified professional technician.

- Cut off power supply of the heat pump before cleaning, examination and repairing . Do not touch the electronic components until the LED indication lights on PCB turn off.

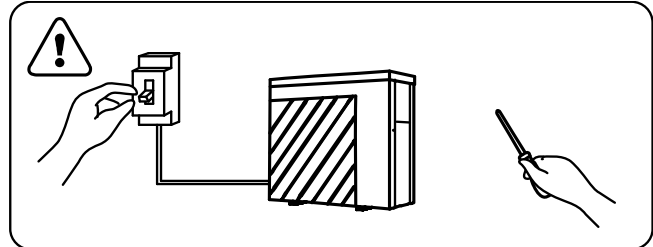

- Please clean the evaporator with household detergents or clean water, NEVER use gasoline, thinners or any similar fuel.
- Check bolts, cables and connections regularly.

2.4.2 Winterizing

In winter season when you don't swim, please cut off power supply and drain water out of the heat pump. When using the heat pump under 2°C, make sure there is always water flow.

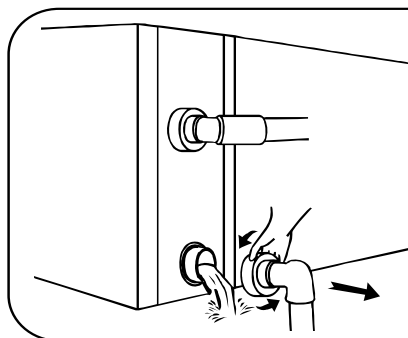

⚠ Important:

Unscrew the water union of inlet pipe to let the water flow out. When the water in machine freezes in winter season, the titanium heat exchanger may be damaged.

➤ 3. Trouble shooting for common faults

FAILURE	REASON	SOLUTION
Heat pump doesn't run	No power	Wait until the power recovers
	Power switch is off	Switch on the power
	Fuse burned	Check and change the fuse
	The breaker is off	Check and turn on the breaker
Fan running but with insufficient heating	evaporator blocked	Remove the obstacles
	Air outlet blocked	Remove the obstacles
	3 minutes start delay	Wait patiently
Display normal, but no heating	Set temp. too low	Set proper heating temp.
	3 minutes start delay	Wait patiently

If above solutions don't work, please contact your installer with detailed information and your model number. Don't try to repair it yourself.

ATTENTION! Please don't try to repair the heat pump by yourself to avoid any risk.

> 4. Failure code

NO.	DISPLAY	NOT FAILURE DESCRIPTION
1	E3	No water protection
2	E5	Power supply exceeds operation range
3	E6	Excessive temp difference between inlet and outlet water (Insufficient water flow protection)
4	Eb	Ambient temperature too high or too low protection
5	Ed	Anti-freezing reminder
6	OFF	Customer Control Switch DIN2 Disconnect
NO.	DISPLAY	FAILURE DESCRIPTION
1	E1	High pressure protection
2	E2	Low pressure protection
3	E4	Phases lack protection (three phase model only)
4	E7	Water outlet temp too high or too low protection
5	E8	High exhaust temp protection
6	EA	Evaporator overheat protection (only at cooling mode)
7	P0	Controller communication failure
8	P1	Water inlet temp sensor failure
9	P2	Water outlet temp sensor failure
10	P3	Gas exhaust temp sensor failure
11	P4	Heating (Evaporator) coil pipe temp sensor
12	P5	Gas return temp sensor failure
13	P6	Cooling (Titanium heat exchanger) coil pipe temp sensor
14	P7	Ambient temp sensor failure
15	P8	Cooling plate sensor failure
16	P9	Current sensor failure
17	PA	Restart memory failure
18	F1	Compressor drive module failure
19	F2	PFC module failure
20	F3	Compressor start failure
21	F4	Compressor running failure
22	F5	Inverter board over current protection
23	F6	Inverter board overheat protection
24	F7	Current protection
25	F8	Cooling plate overheat protection
26	F9	Fan motor failure
27	Fb	Capacitor no charging protection
28	FA	PFC module over current protection
29	8888	Communication failure

APPENDIX 1: HEATING PRIORITY WIRING DIAGRAM (OPTIONAL)

For water pump: Voltage 230V, Capacity ≤500W

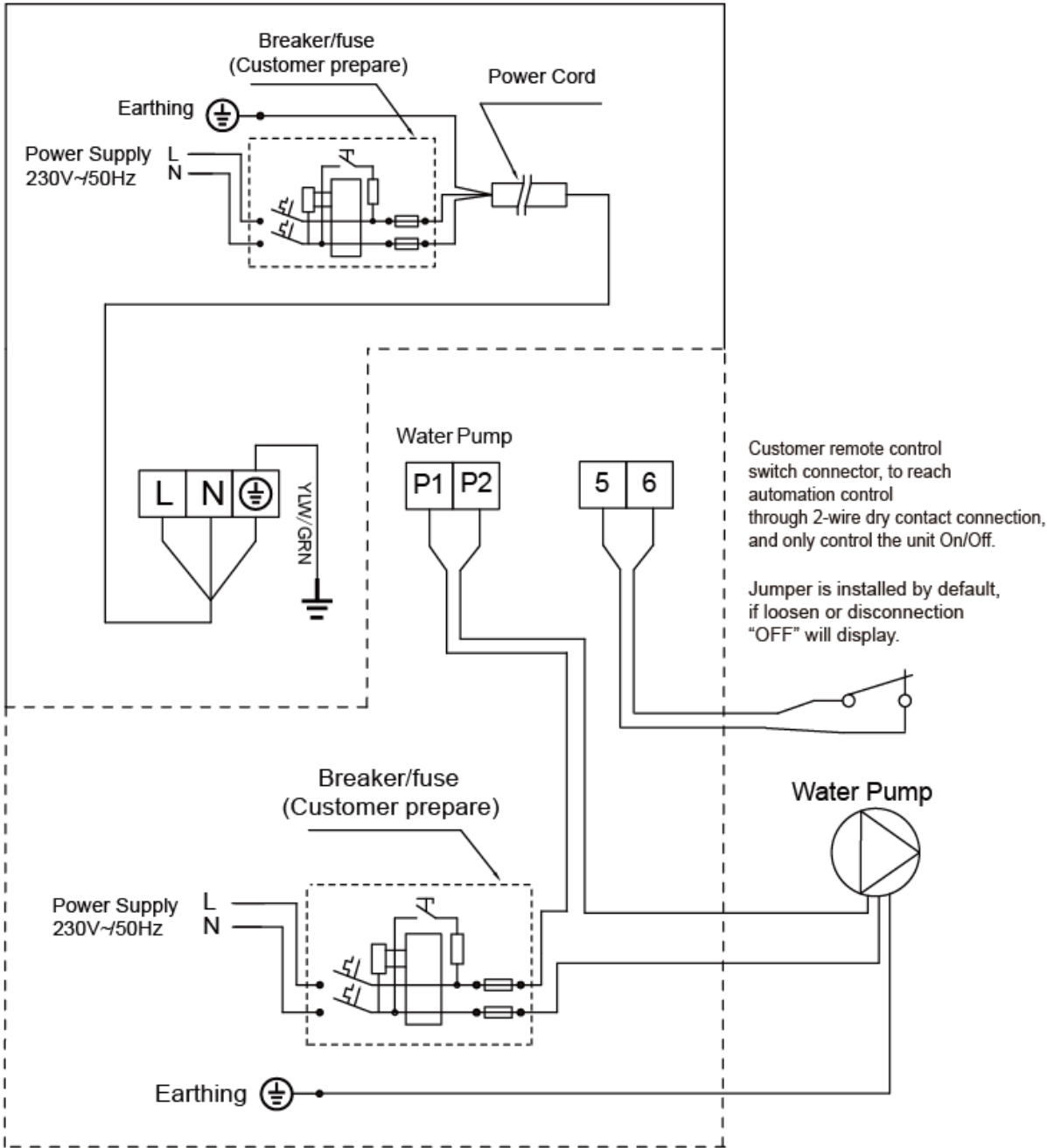

APPENDIX 2: HEATING PRIORITY WIRING DIAGRAM (OPTIONAL)

For water pump: Voltage 230V, Capacity > 500W

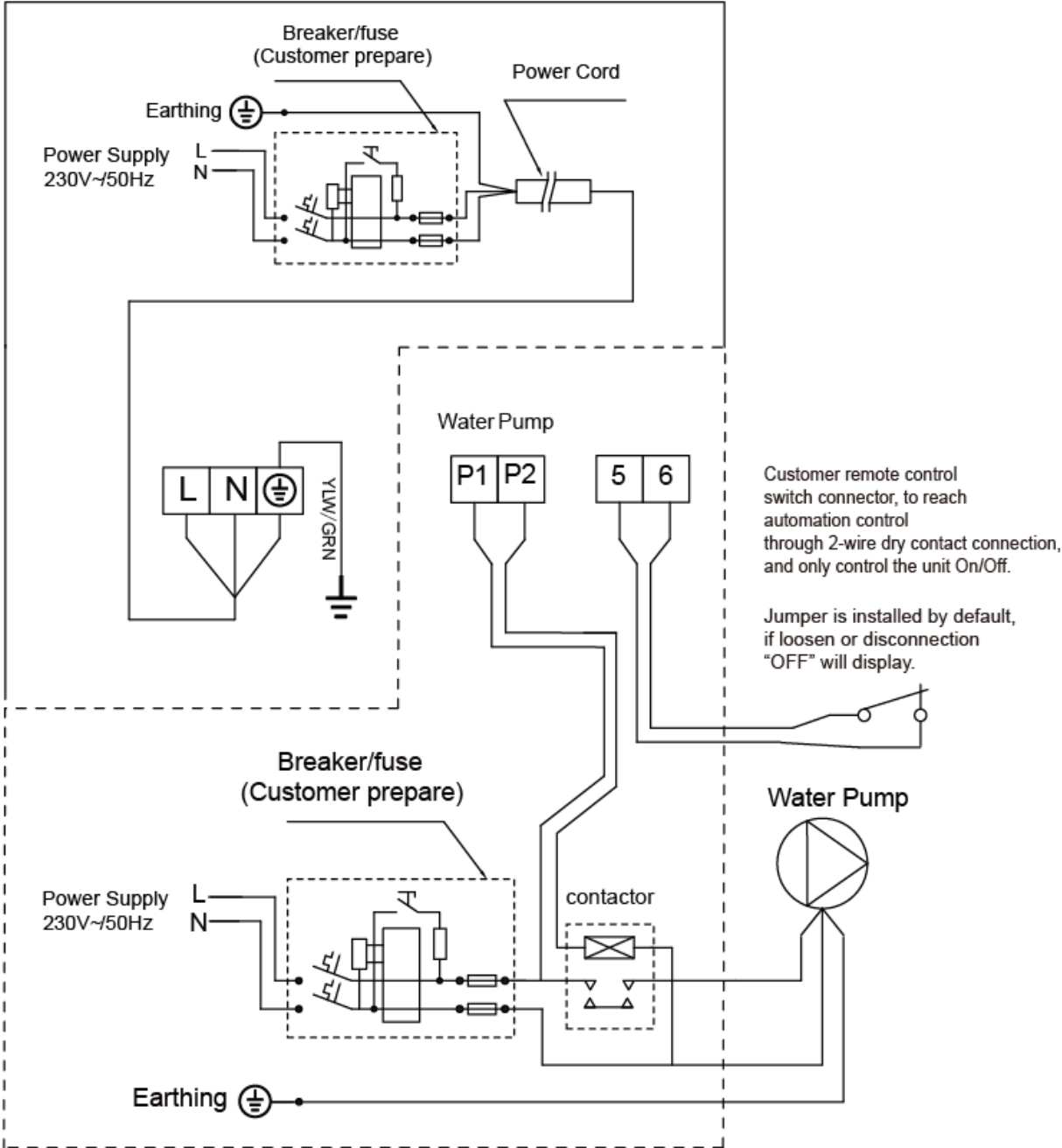

APPENDIX 3: HEATING PRIORITY WIRING DIAGRAM (OPTIONAL)

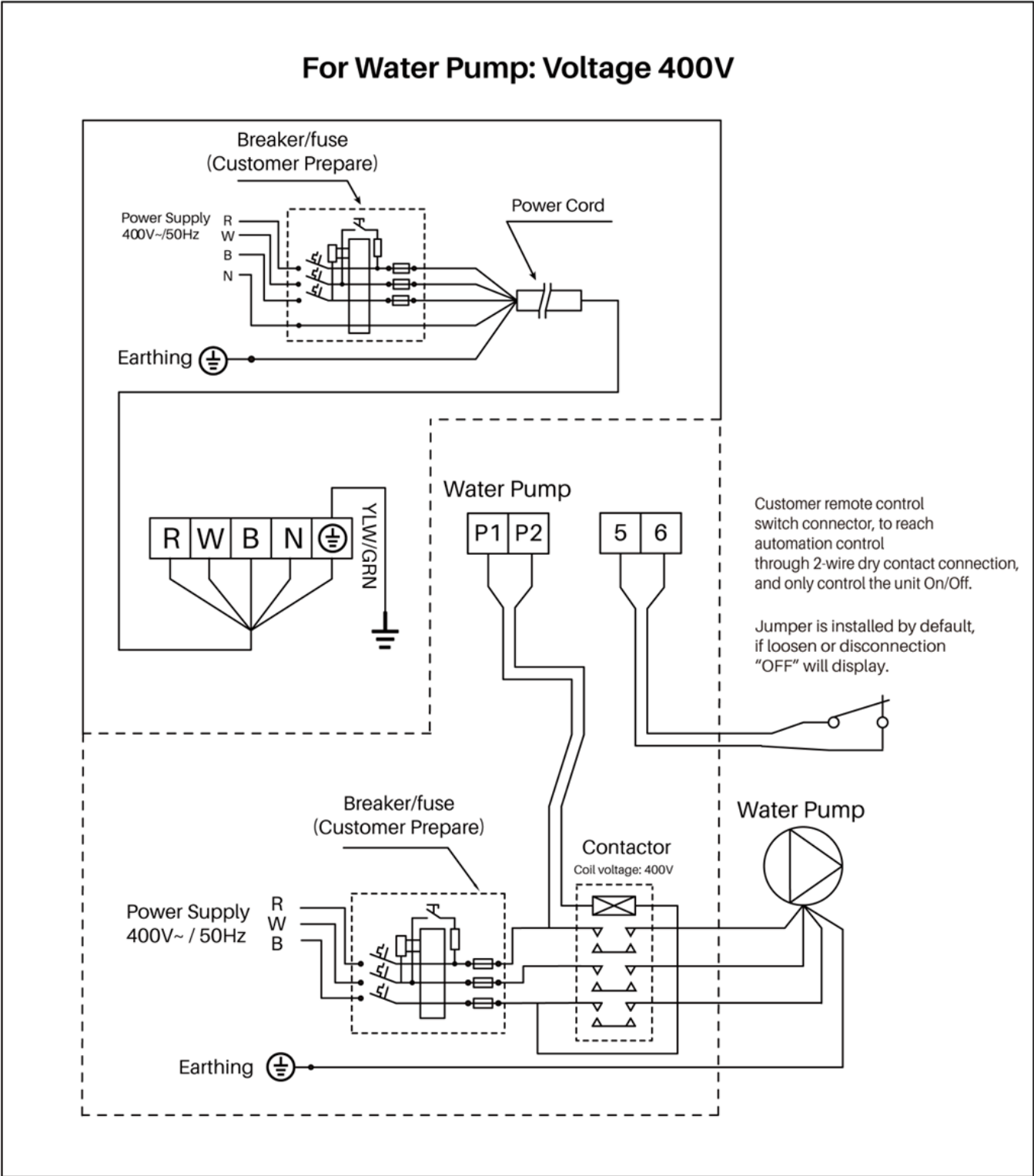

Parallel connection with filtration timer

If the user wants to connect the water pump timer, the installer should connect water pump timer and water pump wiring of heat pump in parallel. So that water pump can start when water pump timer or water pump wiring of heat pump is connected, and water pump will only be switched off when both are disconnected at the same time.

5. Wi-Fi Setting

5.1 APP Download

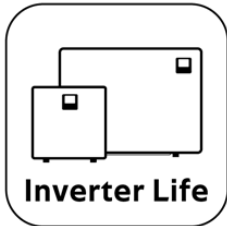

Android Mobile please download from



iPhone please download from



5.2 Account registration

a) Registration by Cell phone number/Email

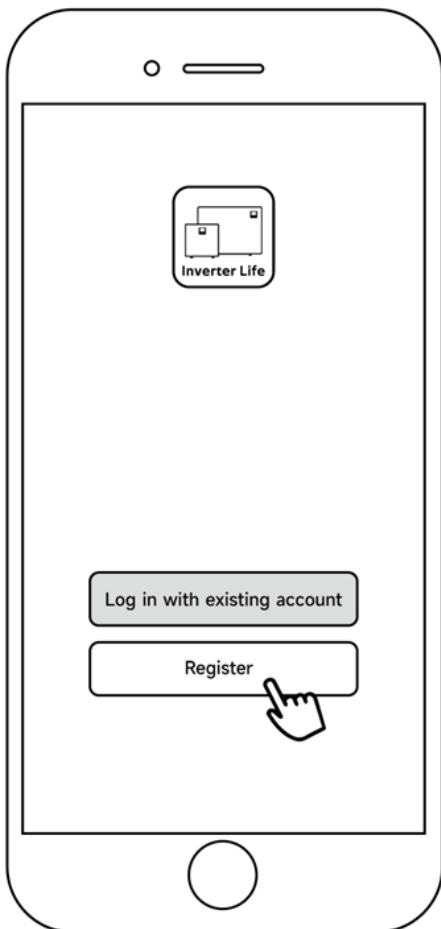

b) Cell phone number registration



5.3 Create family

Please set a name for the family and choose the room of the device.

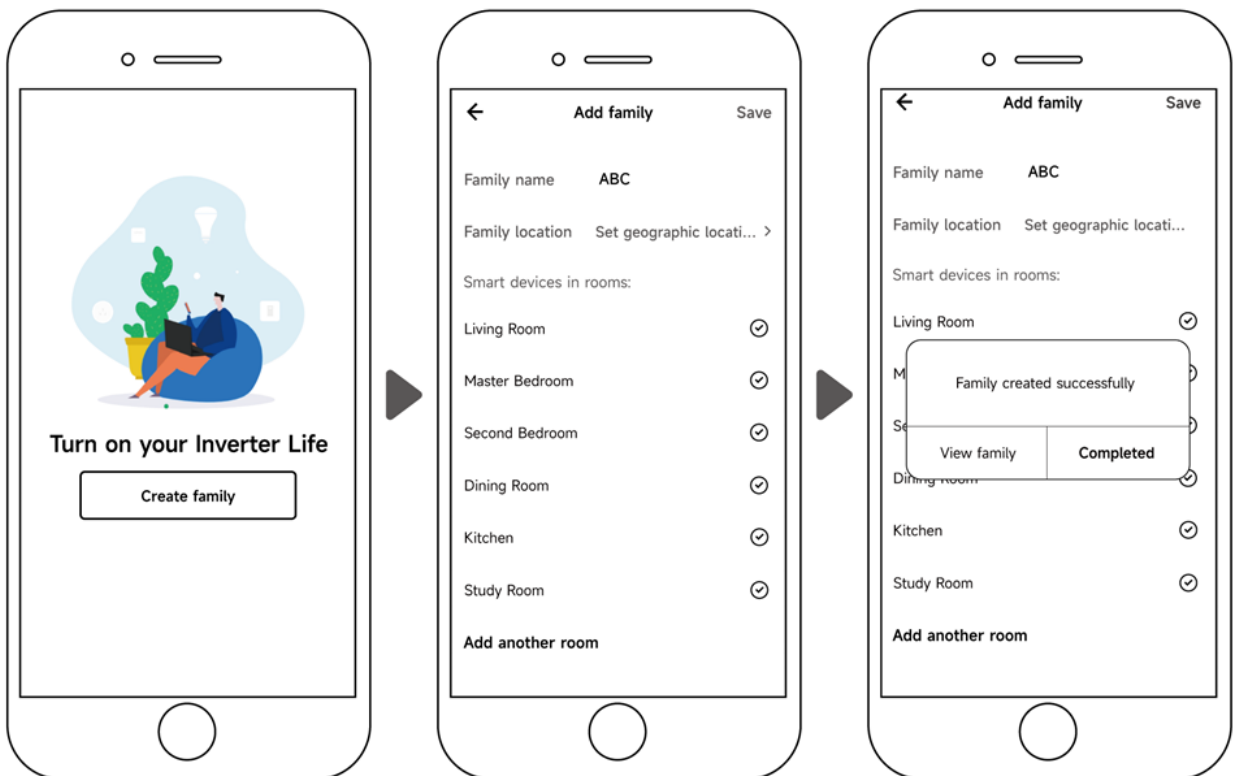



5.4 Three methods of device binding

Please connect your phone to the Wi-Fi network first.



5.4.1 Auto Discovery (Bluetooth)

- a) Please make sure the Bluetooth function is enabled on your phone.
- b) Press  for 3 seconds after the screen unlock,  will be flashing rapidly to enter Wi-Fi binding status.
- c) Click "Add Device", wait for the app to search for the device and then click "add", then follow the instructions below to finish the device binding.

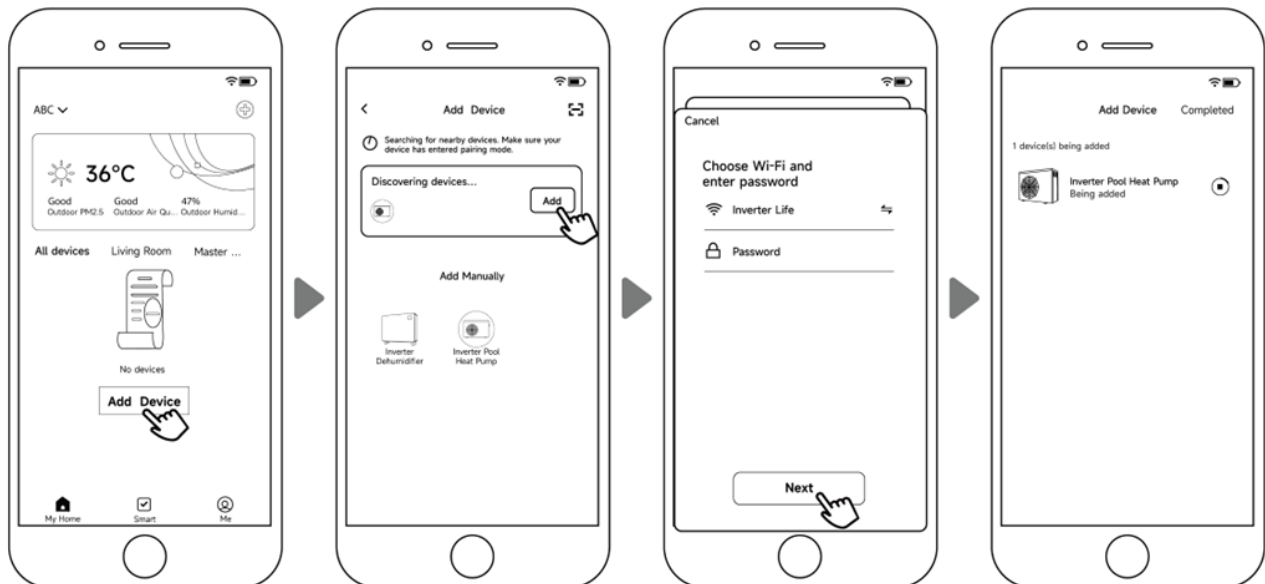



Note:

1. It will take some time to scan, please be patient.
2. Only Wi-Fi modules with Bluetooth functions can use this method

5.4.2 EZ Mode (Easy-connect)

a) Activate the Wi-Fi module

Press  for 3 seconds after the screen unlocks,  will be flashing rapidly to enter Wi-Fi binding status.

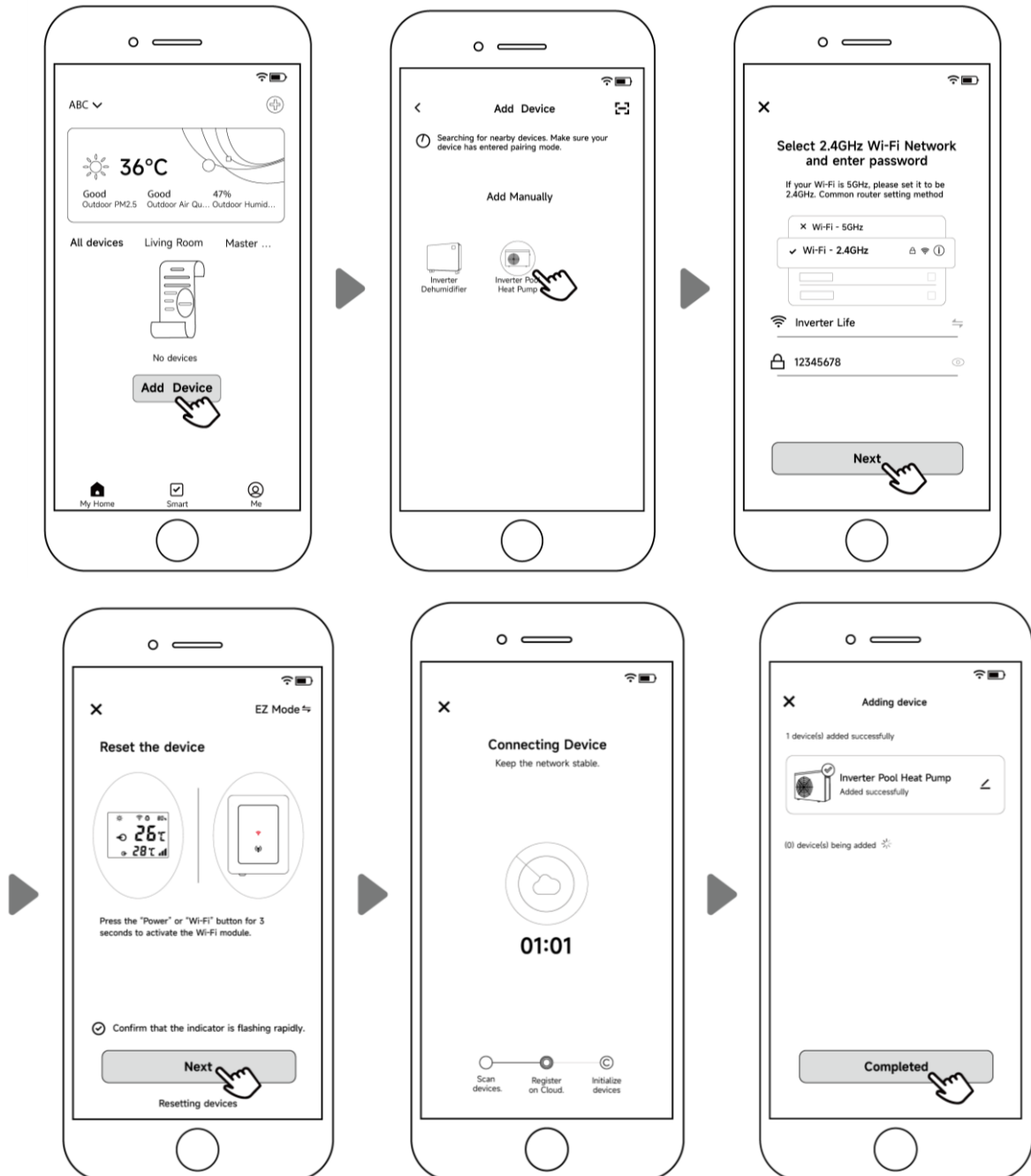

b) Click "Add device", and follow the instructions below to finish binding.  display on the screen once the Wi-Fi connection success.



Note: After allowing the APP to locate, it can read the Wi-Fi name automatically.

5.4.3 AP Mode

Activate Wi-Fi module

- a) Press  for 10 seconds after the screen unlock,  will be flashing slowly to enter Wi-Fi binding status.
- b) Click "Add device", and follow the instructions below to finish binding.  display on the screen once the Wi-Fi connection success.

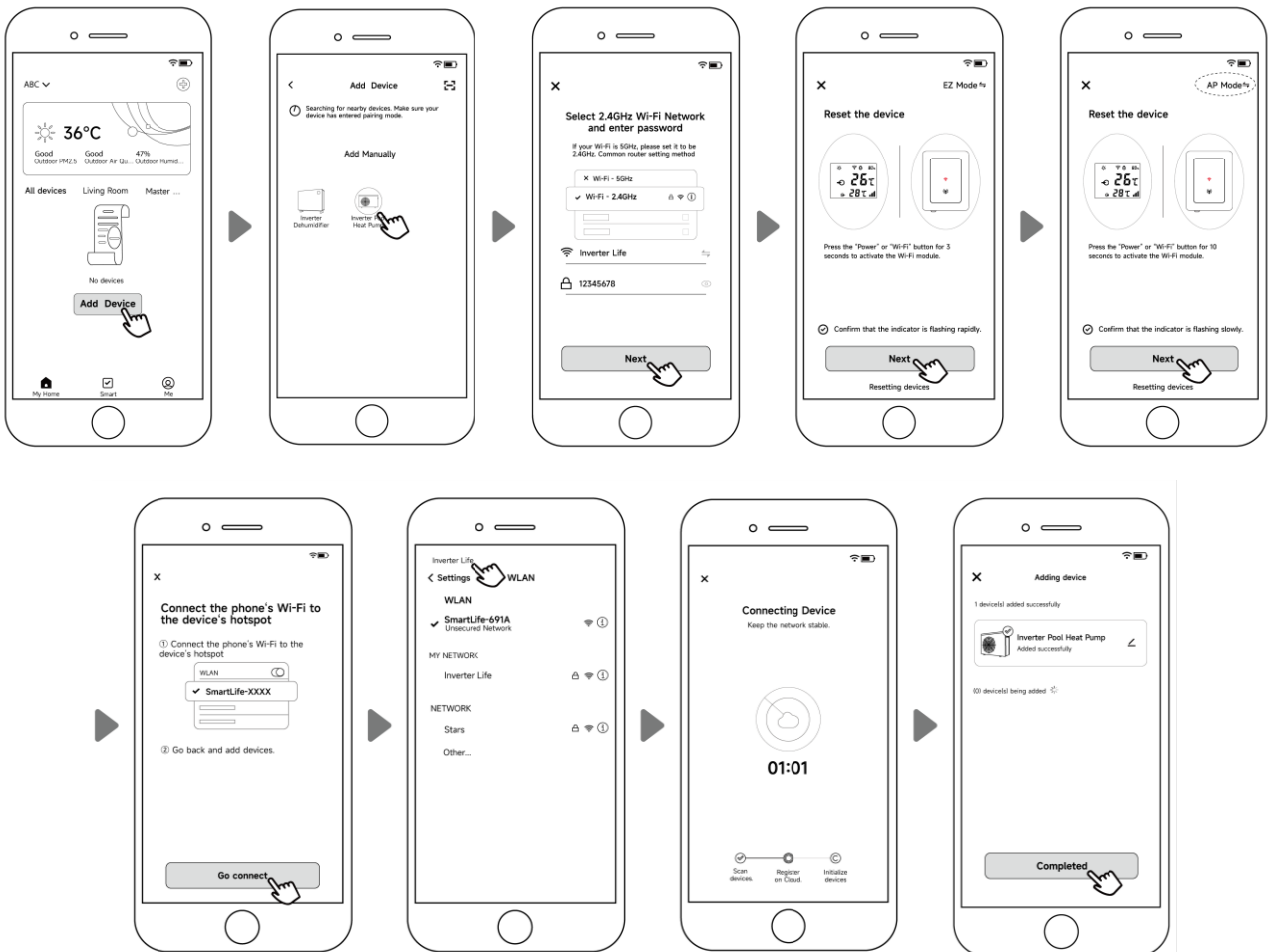



Note: If it doesn't jump automatically, click "Confirm hotspot connection, next".

5.4.4 If connect fails, please make sure your network name and password are correct.

And your router, mobile phone and device are as close as possible.

5.4.5 Wi-Fi rebinding (When Wi-Fi password changes or network configuration changes)

Press  for 10 seconds,  will be flashing slowly for 60 seconds. Then  will be off. The original binding will be removed. Follow steps above for rebinding.

Remarks: Please make sure the router is configured at 2.4 GHz.

5.5 Operation instructions

The following instructions are for heat pumps with heating and cooling functions.

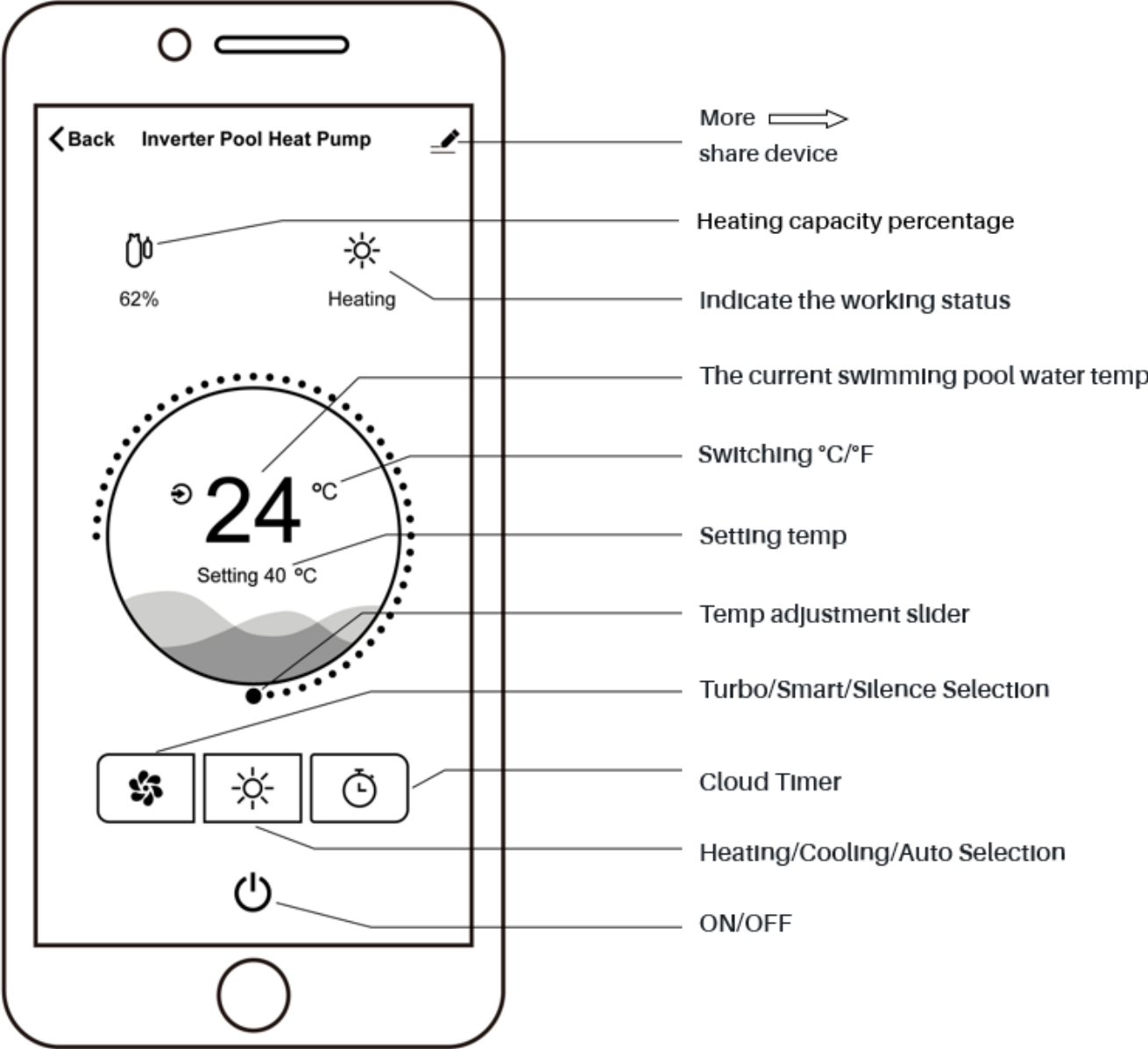

5.6 Share devices with your family members

After binding, if your family members also want to control the device.

Please let your family members register the APP first, and then the administrator can operate as below (The following pictures are for reference only):

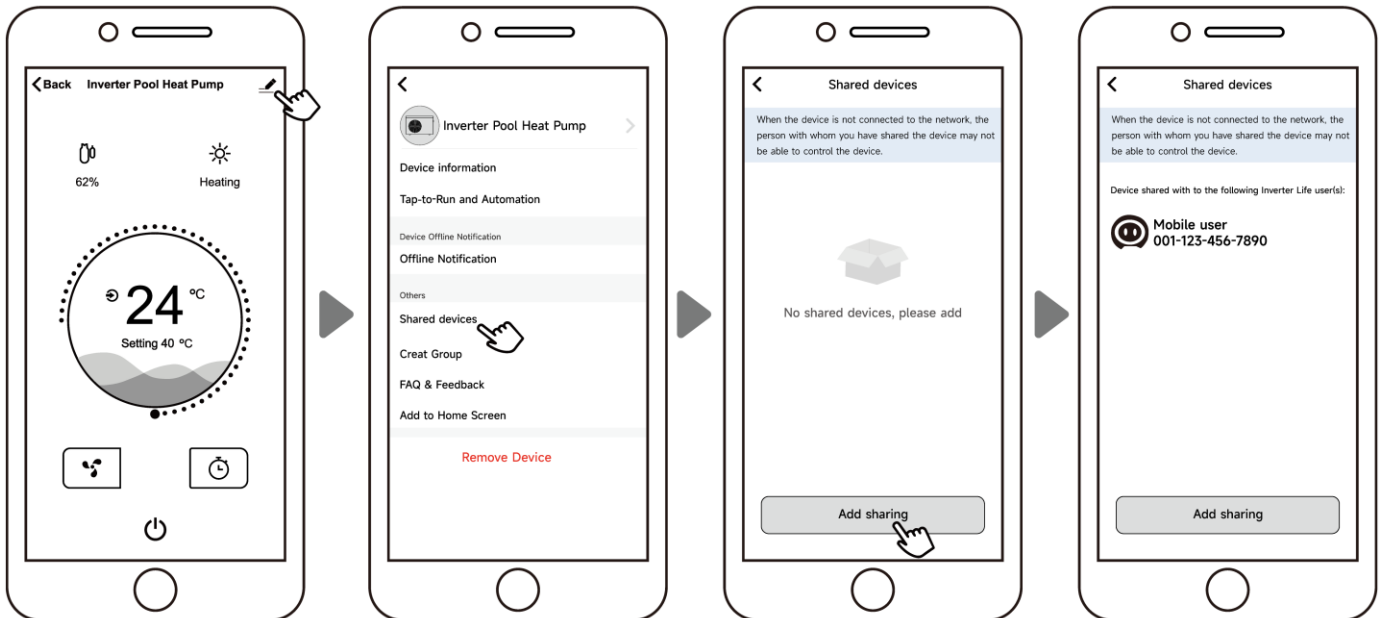

Then your family members will see this heat pump once they log in to the APP.

Notice: 1. The weather forecast is just for reference.

2. APP is subject to update without notice.

DESCRIPTION

An all in one system for autonomous control of heat pumps in line with the filtration system. This unit permits the heat pump to run outside of filtration hours set by sanitation timers allowing for full automatic heat demand.

OPERATION

The VortexLink is designed to switch a 240Vac pump rated to 10 Amps 2400 watts from the switch inputs. This unit is designed to be connected to a chlorinator and the outputs from heat pumps. VortexLink is fitted with an LCD screen which displays whether the pump is on and whether the chlorinator or heat pump is demanding the pump to be operating.

HEAT DEMAND

A heating device, whatever it is, is designed to heat the pool water only when the water circulates. Most of the time, a pool is filtered between 6 and 8 hours a day. But such a time can't be sufficient sometimes to maintain the water at the desired temperature, depending on the seasons. This is the reason why the heat pump is equipped with the "sample" function that will manage the temperature of the pool. Every hour (times vary depending on the heat pump model) the filtration pump is started for 5 minutes. If after 5 minutes, the temperature of the water is above the required temperature, the filtration turns off for one more hour. Otherwise, the filtration and the heat pump are going to keep on operating until the desired temperature is reached.

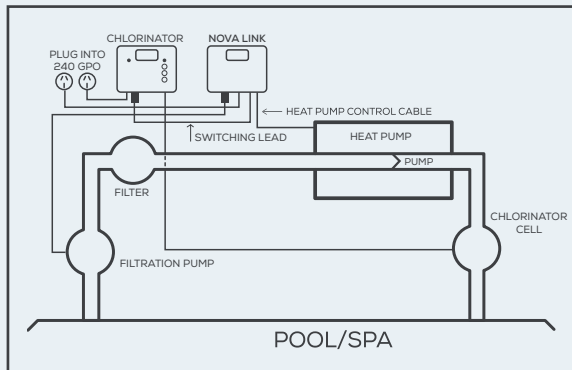

INSTALLATION INSTRUCTIONS

Mounting

Find a suitable location to mount the VortexLink box. Ideally, as with all pool equipment, it should be installed out of direct weather and no closer than 3m from the water's edge and a minimum 600mm above ground. Fix the mounting bracket to a solid structure and slide the VortexLink on, keeping in mind that the power cable is 1.8m long and should be plugged directly into a general power outlet, not into an extension lead.

Pump

The filtration pump plugs into the 240V outlet beneath the VortexLink.

Heating Demand

Connect the heat pump control cable from the VortexLink to the heat pump, refer to the heat pump manufacturer's instructions and the below diagram for the appropriate connection and note that damage caused by incorrect connections will void warranties.

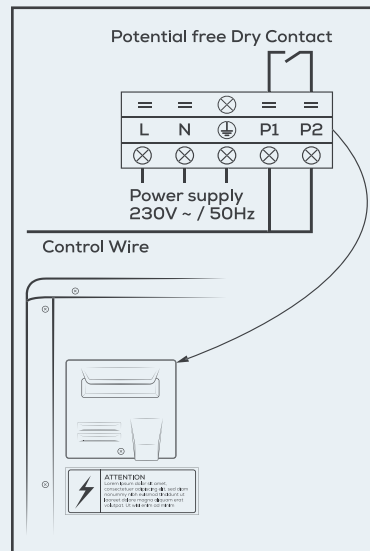

WARRANTY

This range of product is covered by a limited 2 year warranty against component failure or faulty workmanship from the date of installation.

Faulty units should be returned in the first instance to the dealer from which the unit was purchased.

Damage to the unit due to misuse, power surges, lightning strikes or installation that is not in accordance with the manufacturer's instruction may void the warranty.

Warranty does not include on-site labour or travel costs to or from installation site.

Customer Record. (To be retained by the customer)

Dealer/Installer Name _____

Serial Number _____

Date Installed _____



HEATSEEKER VORTEX SWITCH

OPERATION & INSTALLATION INSTRUCTIONS

DESCRIPTION

A plug and play option for heat pump systems with independent circulation pumps. Can be fitted during the installation of the heat pump.

OPERATION

The VortexSwitch is designed to switch a 240Vac pump maximum rated to 9.98 Amps 2395 watts from the switch inputs. This unit is designed to be plugged into a general power outlet and the heating priority connections on the heat pump.

HEATING PRIORITY

The heat pump is designed to heat or cool the water of the pool only when the water circulates through it. By connecting the VortexSwitch to the heat pump, and then the circulation pump to the VortexSwitch, the heat pump will control when the circulation pump is run. This system allows the heat pump to maintain the set-point temperature in either heating or cooling mode.

Every 60 minutes, the circulation pump is started for 2 minutes to sample the water temperature. If after 2 minutes, the temperature of the water is below/above the required set-point temperature (depending if in heating or cooling mode), the circulation pump will be turned off for a further 60 minutes before sampling the water temperature again.

If the heat pump senses that the water has cooled/heated below/above the temperature set-point, the circulation pump and the heat pump will continue to operate until the desired set-point temperature is reached.

By following the instructions in the heat pump instruction manual, setting a start and stop time will ensure that the heat pump is not sampling the water temperature and running throughout the night if running noise is a factor.

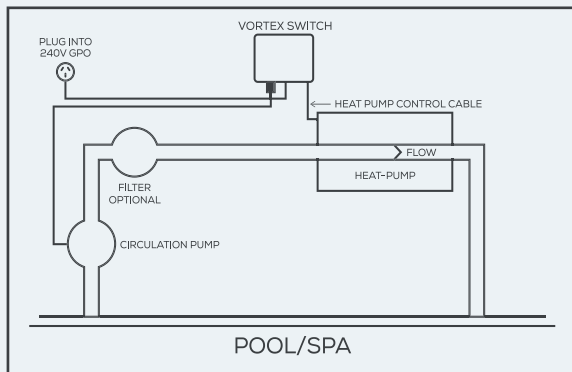

INSTALLATION INSTRUCTIONS

Mounting

Find a suitable location to mount the VortexSwitch box. Ideally as with all pool equipment it should be installed out of direct weather and no closer than 3m from the water's edge and a minimum of 600mm above ground. Lift up the two mounting tabs and use two appropriate screws to mount the VortexSwitch box to the wall, keeping in mind that the power cable is 1.8m long and should be plugged directly into a general power outlet, not into an extension lead.

Pump

The circulation pump plugs into the 240V outlet beneath the VortexSwitch.

Heating Priority

Connect the heating priority cable from the VortexSwitch to the heat pump, refer to the heat pump manufacturer's instructions and the below diagram for the appropriate connection and note that damage caused by incorrect connections will void warranties.

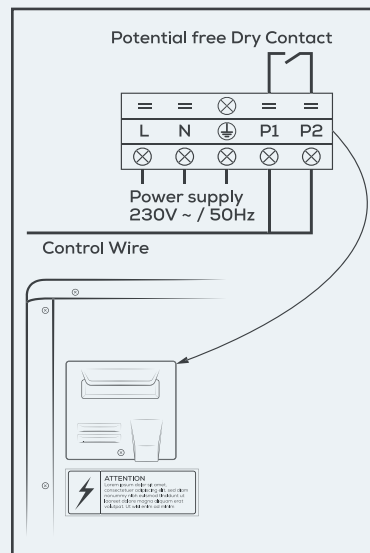

WARRANTY

This range of product is covered by a limited 2 year warranty against component failure or faulty workmanship from the date of installation.

Faulty units should be returned in the first instance to the dealer from which the unit was purchased.

Damage to the unit due to misuse, power surges, lightning strikes or installation that is not in accordance with the manufacturer's instruction may void the warranty.

Warranty does not include on-site labour or travel costs to or from installation site.

Customer Record. (To be retained by the customer)

Dealer/Installer Name _____

Serial Number _____

Date Installed _____

The factory reserves the final interpretation right.

And keep the right to stop or change product specification and design without prior notice at any time, no need to bear the resulting obligations.



Version: Gd3lr32