

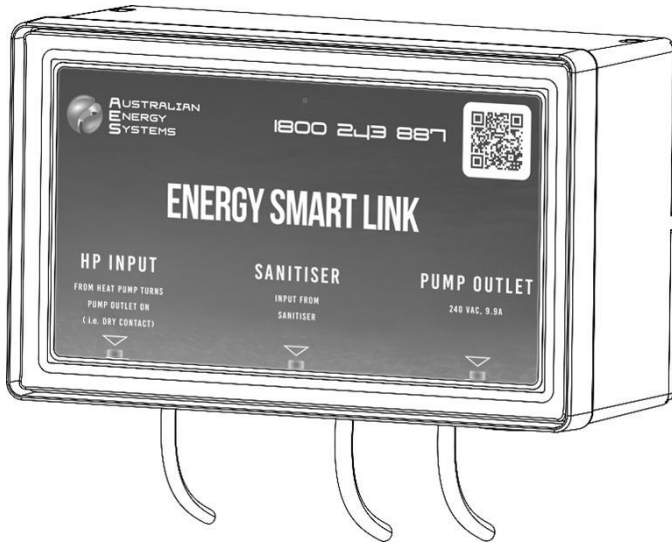

Energy Saving Link (ESL)

Heat Pump Controller

Instruction Manual



Energy Saving Link Controller by Australian Energy Systems



www.australianenergysystems.com.au



+61 7 32992700



TABLE OF CONTENTS

1. SAFETY	1
2. GENERAL OVERVIEW	1
3. SPECIFICATIONS	2
4. MAINTENANCE	2
5. HELPFUL HINTS	2
6. CONTENTS	2
7. TOOLS NEEDED	3
8. INSTALLING THE ESL CONTROL SYSTEM	3
9. OPERATION OF THE ESL CONTROLLER	4
10. ESL CONTROLLER TROUBLESHOOTING	5
11. PART NUMBERS	5
12. WARRANTY	6
13. DISCLAIMER	6
14. NOTES	6

1. SAFETY

Important Warnings: This manual contains important information about the installation, operation, and safe use of this product. This information should be given to the owner and/or operator of this equipment. When installing and using this electrical equipment, basic safety precautions should always be followed. Failure to follow safety warnings and instructions in this manual can result in serious injury and/or damage to your equipment. Read and follow all warning notices and instructions which are included in this manual.

- The ESL controller case internally contains live components. There is a danger of electric shock if opened. If the power cord is damaged then it should be replaced by the manufacturer, their agent or similar qualified person, to avoid a hazard.
- The product shall be installed by a qualified person in according to AS/NZS 3000 wiring rules.
- The ESL controller should be installed in the correct pool zone and connected to supply via a power outlet that is protected by a residual current device (RCD) having a rated residual operating current not exceeding 30mA. The power outlet should have a degree of protection suitable for the pool zone.
- To reduce the risk of injury, do not permit people (including children) with lack of experience and knowledge, to use this appliance unless they have been given supervision or instruction concerning use of the appliance.
- To reduce the risk of accidents or incidents, service on the unit should only be performed by a qualified pool service professional, after disconnecting it from the mains power supply.

Important Safety Instruction: To reduce the risk of injury, do not permit young children to use this product unless they have been trained by the person responsible for their safety and they acknowledge their ability to use such equipment. To reduce the risk of accidents or incidents, service on the unit should only be performed by a qualified pool service professional.

DO NOT PLUG IN IF CARTON IS WET.

Should you require further information visit www.australianenergysystems.com.au



When using the ESL Controller Box:

- Observe all applicable local, state, and federal safety regulations.
- Take proper precautions with prescribed environmental and operational conditions.

2. GENERAL OVERVIEW

Congratulations on your recent purchase of your Energy Saving Link Controller. Please take a moment to read through the entire manual before installing your new unit. Your ESL Controller control system must be installed and operated as specified.

While every effort has been made to ensure that the information contained in this guide is accurate and complete, no liability can be accepted for any errors or omissions. Australian Energy Systems reserves the right to change the specifications of the hardware and software described herein at any time without prior notice.

The ESL Controller is a heat pump and sanitiser interface that enables smart pump switching with an isolated circuit between sanitiser and heat pump inputs, saving you money on your swimming pool running costs.

3. SPECIFICATIONS

SPECIFICATIONS	
Volts Input (Vac)	220-245
Amps Input - Max. (Aac)	10.00
Amps Output Pump Max. (Aac)	9.90
Total Power Consumption (W)	24
Frequency (Hz)	50/60
ESL Box Dimensions (mm)	220W x 135H x 90D
Power Cord	10A Australian Approved + piggy-back type
Wall Mounting	Simple Click On – Clip OFF
Ingress Protection Rating	IP35
Unit Shipping Dimensions (mm)	310W x 230H x 115D
Net Weight (kg)	1.0

***NOTE:** Certain specification may change without notice for reasons of improvement or better performance.

4. MAINTENANCE

It is important to maintain your ESL Controller, please periodically check for any wear on the leads to and from your box and for any leaks from any associated close by pool equipment have which may impact it.

5. HELPFUL HINTS

Read and Keep your Manual in a safe place.

6. CONTENTS

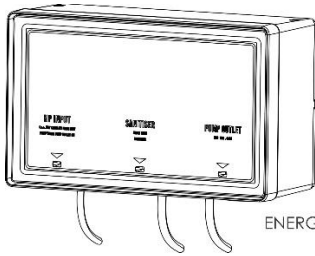

The Installation & Operating Instructions



2 x Red Wall Plugs with Screws

ENERGY SMART LINK Controller

7. TOOLS NEEDED



Drill with 6.0mm drill bit



No.2 Phillips head screwdriver

8. INSTALLING THE ESL CONTROLLER SYSTEM

Installation Diagram

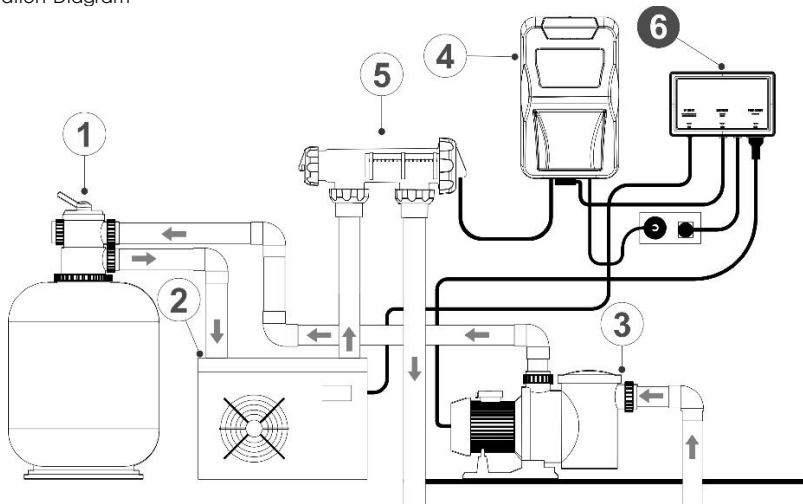

1 ● Pool Filter

2 ● Heat Pump

3 ● Pool Pump

4 ● Pool Sanitiser

5 ● Cell Housing

6 ● ENERGY SMART LINK Controller

STEP 1: Remove the contents from the box and carefully plan all steps using the installation diagram and by reviewing the steps below.

STEP 2: Position the ESL Controller as indicated in the installation diagram, ensuring it is NOT too close to other equipment or power outlets but close enough to the Sanitiser, Pump, and Heat Pump power supply so the piggy-back power cord can plug in to its socket outlet and the Heat Pump Interface Cable can ready the heat pump.

STEP 3: Attach the ESL Controller to the wall by removing the simple "Click ON – Click OFF" wall mounting bracket that is attached to the controller case. Use the wall plugs and screws provided.

3.1: Click OFF the wall bracket clip

3.2: Pull the wall bracket away from case.

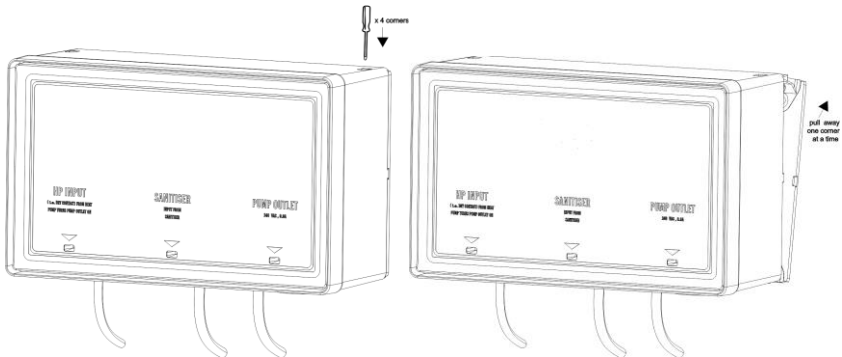

3.3: Mount the bracket to the wall

3.4: CLICK ON the case to the wall bracket

This unique design keeps the controller case unexposed to any possible water entry.

STEP 4: HP INPUT: Fit the two pin terminals on the HP Input cable to the potential free dry contacts in the heat pump. This is a signal from the heat pump to turn the pool pump ON.



When connecting to the Heat Pump ensure the two pin terminals connect to a potential free contact. This connection must be performed by the Heat Pump installers only. Any voltage on this connection will lead to ESL Controller failure and void warranty.

STEP 5: SANITISER INPUT: Fit the piggyback point from the ESL Controller Sanitiser Input to the AC Socket outlet on the Sanitiser.

STEP 6: PUMP OUTLET: Plug the power cord from the pump into the AC Socket on the base of the ESL controller

STEP 7: Connect the plug top at the rear base of the ESL Controller to a wall power socket.

9. OPERATION OF THE ESL CONTROLLER

The ESL controller will operate under the below conditions indicated by the LED display:

Heat Pump Demand	Sanitiser Demand	Pool Pump Status
OFF	OFF	OFF
OFF	ON	ON
ON	OFF	ON
ON	ON	ON

10. ESL CONTROLLER TROUBLESHOOTING

	Fault Condition	Potential Cause	Remedy
6.1	ESL Controller not turning pump ON	ESL Controller inputs not plugged in	Check that the pump is securely plugged into ESL Controller AC socket. Check that an input signal is getting received. From HP Input or Sanitiser. Check that ESL Controller power cord is plugged in to a wall socket and there is power at that point.
6.2	ESL Controller HP Input LED is not ON	No demand ON signal from the Heat Pump.	Check that the HP input cable is receiving a closed contact from the Heat Pump. The ESL Controller sends a 5Vdc signal to the Heat Pump and receives it back to turn ON the pool pump.
6.3	ESL Controller Sanitiser LED is not ON	Sanitiser power lead is not plugged in securely to the sanitiser or no demand ON signal from the Sanitiser.	Check that the Sanitiser piggyback plug is securely fitted to the sanitiser and that there is output from the sanitiser to turn the pool pump ON.
6.4	ESL Controller Pump Outlet LED is not ON	No signal for it to turn on.	Check that there is a demand ON signal from the Heat Pump and Sanitiser.

11. PART NUMBERS

CODE	DESCRIPTION
------	-------------

N00305-1	Base Body
N00306	Wall Bracket
N01364	Power Cord - ESL Controller c/w Piggyback Socket
N01379	Front Sticker - ESL Controller LED VERSION
N01400	Case Front Cover
N01401	PCB – ESL Controller

12. WARRANTY

This product is warranted for (24) twenty four months against defects in workmanship and materials if used for its intended purpose and maintained according to instructions. This warranty is limited to repair or replacement, depending on the problem of the product. If the product is found to have been misused or damaged due to water entry/mechanical damage/accidental damage, this will not be covered under warranty, and, in such cases, no warranty will apply.

What is covered? Repairs/parts/factory labour, or a replacement unit if applicable.

What is not covered? Damage due to accident, misuse, water penetration of the handheld enclosure, tampering, or lack of prescribed maintenance is not covered under this limited warranty.

Should you need to lodge a warranty with the AES Service department, ensure to include the product serial number, purchase date, and type of failures. If returned to AES, ensure proper packaging so that no additional damages occur during transport. The customer is liable to return the ESL Controller to AES.

This limited warranty is the sole and complete warranty for AES and shall be limited to the cost of the meter. In no event shall Australian Energy Systems be liable for incidental or consequential damages.

13. DISCLAIMER

AES has made every attempt to ensure the accuracy and reliability of the information provided in this manual. However, the information is provided "as is". We shall not be liable for any loss or damage of whatever nature (direct, indirect, consequential, or other), which may arise due to the use of this product.

14. NOTES



Energy Saving Link by Australian Energy Systems

Phone +61 7 32992700

**Unit 17/6 Maunder St,
Slacks Creek QLD
Australia 4127**

www.australianenergysystems.com.au



**Designed and
Made in
AUSTRALIA**